

ISUZU 'GRAFTER' N35.150(ST) 3.5T GVW

4X2 RIGID SINGLE REAR WHEELS TIPPER

EURO 4

UK STANDARD VEHICLE PLATED WEIGHTS

GVW 3500KG
GTW 7000KG* †

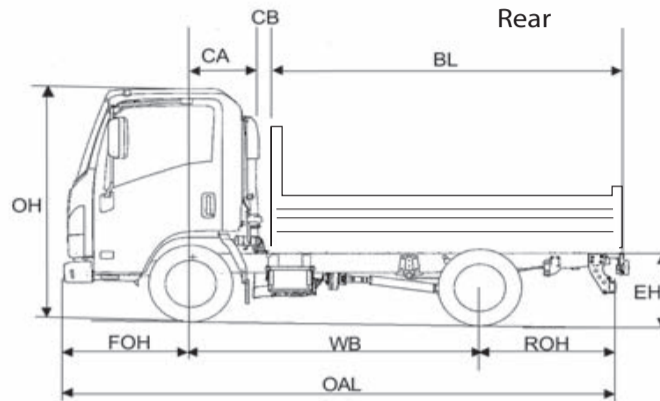
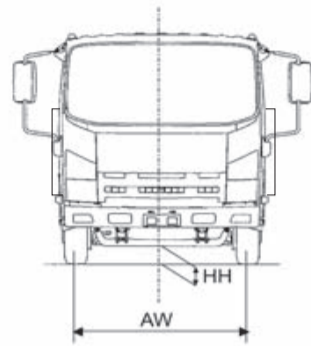

UK AXLE DESIGN WEIGHTS

Front 1900KG
Rear 2000KG

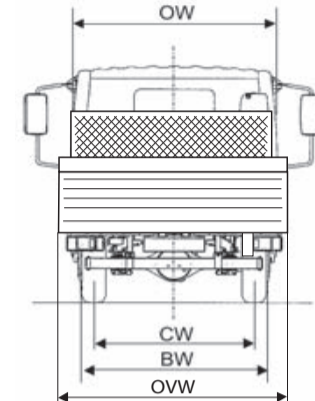

WEIGHTS (KG)

CAB TYPE

day

WHEELBASE (WB)

2480

Vehicle Mass Unladen	Front Axle	1450
	Rear Axle	835
Total		2285
GVW		3500
Max. Permissible Trailer Weight		3500*
Payload		1215

DIMENSIONS (mm)

Overall Length	OAL	4870
Overhang	Front FOH	1110
	Rear ROH	1380
Cab Gap	CB	130
C/L Front Axle to Rear of Cab	CA	430
Body Length	BL	3200
Overall Vehicle Width	OVW	1780
Chassis Frame Width		700
Body Width		1780
Height of Body Sides		400
Cab Width	OW	1770
Overall Height (Unladen)	OH	2145
Body Bed Height	EH	940
Minimum Road Clearance	HH	190
Track	Front AW	1385
	Rear CW	1395
Rear Axle Width	BW	1603

BODY SPECIFICATION

- All steel tipper body with rear tailgate hinged top and bottom
- Steel safety prop
- Sheet steel body floor
- Full cab height contoured tubular steel headboard, lower half covered in 2mm mesh infill with full width cross bars. Ladder loops on top rail
- N/S body mounted foldable access ladder
- Side mounted rope hooks for easy load restraint
- Body, frame and underframe fully corrosion protected by electro-cathodosis process
- Underframe, frame, headboard, floor and pillars finished in Isuzu Gloss Black using electrostatic process
- Body sides finished in Isuzu Gloss Arc White using electrostatic paint process
- Spring locked flush fitting plastic latches
- 24V electro-hydraulic tipping pump system with underfloor scissor type ram and subframe
- High quality poly plastic rear wings and brackets

† If you intend operating regularly at 7 tonnes GTW refer to the Isuzu Truck (UK) Limited technical department before ordering.

* Driver licence and tachograph regulations apply.

N35.150(ST)/0908/GW/3K

1. Unladen weights exclude fuel, driver, spare wheel + carrier, tool kit and jack. (Tolerance +/- 3%).
2. Isuzu Truck (UK) Ltd. shall have no liability whatsoever should the information supplied have incorrect data, descriptions or illustrations.

ISUZU 'GRAFTER' N35.150(ST) 3.5T GVW

4X2 RIGID SINGLE REAR WHEELS TIPPER

EURO 4

N35.150(ST) 3.5T

Mechanical Specification

(standard equipment)

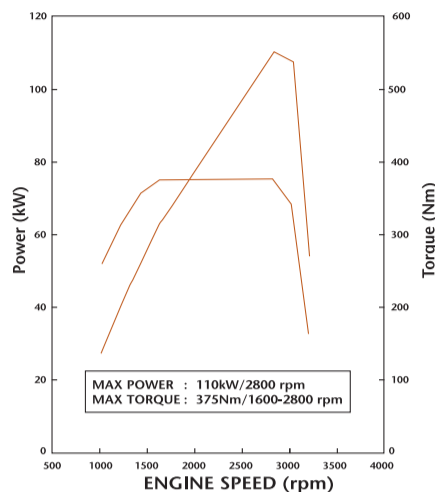

Engine 4JJ1TC

- Isuzu turbo intercooled DOHC 4 cylinder diesel (Euro 4)
- Bore: 95.4mm
- Stroke: 104.9mm
- Capacity: 2999cc
- Max Power: 110kW (150bhp) at 2800rpm
- Max Torque: 375Nm between 1600-2800rpm
- Injection Type: Common rail
- Euro 4 Compliance: EGR (Exhaust Gas Recirculation) with DPD (Diesel Particulate Defuser)

Fuel Tank

Capacity: 75 litres

Transmission

- 5-speed synchromesh MYY5T overdrive
- Ratios: 1st 5.315:1
2nd 3.053:1
3rd 1.655:1
4th 1.000:1
5th 0.721:1
reverse 5.068:1
- Rear Axle Ratio: 4.10:1
- Tyres: 205R16C - radial, spare wheel and carrier
- Wheels: Single rear wheel 5.50J x 16, 6-stud

Cab Exterior

- New aerodynamic Isuzu hexapod design white all steel cab
- Manual tilt to 45 deg.
- Laminated windscreen
- Plastic resin non-slip entry steps
- 90 deg. opening cab doors
- Zinc galvanised cab frame structure
- 2 flush mounted halogen headlamps with side mounted indicators
- Front tyre mudguards with spray suppression
- Steel reinforced composite front bumper with fog lights
- Chrome radiator grille
- Keyless door entry and immobiliser

Frame

Ladder type channel section straight side rails, riveted upper flanges

Cooling

Radiator: Tube and fin type with fan and viscous clutch

Clutch

300 mm diaphragm type with hydraulic actuation

Cab Interior

- Flame resistant interior trim
- Vinyl floor matting
- Pillar mounted entrance grab handles both sides
- SRS air bags, driver and passenger

Seats (all cloth)

- Drivers fully adjustable with head restraint
- Dual passenger seat with folding back
- Driver and outer passenger retractable diagonal seat belts, with pre-tensioner
- Centre seat lap belt

Vision

- Large foldable door mirrors
- Interior rear view mirror on
- Driver and passenger sun visors

- Deep cut side windows to reduce blind spots
- Electric windows with driver control and lock

Heating & Ventilation

- 4-speed blower
- Multiple cab vents

Axles

Front: Independent
Rear: Banjo fully floating

Suspension

Front: Independent coil spring and hydraulic shock absorbers
Rear: Parabolic alloy steel leaf springs with hydraulic double acting telescopic shock absorbers

Steering

- Relay box and rack & pinion with full integral hydraulic power assistance
- Tilt and telescopic steering column

Brakes

System: Divided hydraulic servo-assisted with load sensing
Front: 265 mm ventilated discs with asbestos free pads
Rear: 290x75 mm drum with twin actuation self-adjusting asbestos free linings
Park: Mechanical drum brake rear of transmission

Instruments

- Speedometer with odometer & trip
- Rev counter
- 9 Metre remote 'Wanderlead' tipper control stored in cab
- Gauges: Fuel level and coolant temperature

Switches & Electrical

- Steering column mounted combination switch for indicators, headlamps (high beam), side and headlamp, front and rear fog lamps
- Brake warning buzzer
- Wiper and washer (2-speed and intermittent)
- Exhaust brake
- Steering wheel horn switch
- Hazard lights
- Head lamp levelling

- Interior light
- Key operation for quick cold start, start and stop
- Engine quick warm up
- Cigarette lighter
- Central locking
- Reverse warning buzzer in cab
- DPD engage
- Fast engine idle
- Chassis/battery mounted tipper system isolating switch

Warning Lamps

- Battery charge
- Oil pressure
- Check brake system
- Low fuel
- Glow plug operation
- High beam and indicators
- Parking brake on
- Exhaust brake operation
- Fuel/water separator
- Check engine
- DPD engaged/warning
- Service warning
- OBD
- Front and rear fog lamps
- Tipping system warning light

Tool Kit

4000 kg jack, with a small selection of hand tools

Radio

RDS Radio/CD Player package

Storage Space

- Compartment box
- Centre console tray
- Door pockets
- Centre facia pocket
- Pop out type cup holder
- Overhead roof shelves
- Card holder

Ancillaries

Starter: Reduction type 24 V – 4.0 kW
Alternator: 24 V – 50 Amp
Quick Start: 4 glow-plugs on start relay
Battery: 2 x 12 V – 75 AH (maintenance free)
Tipping System: 24 V – pump with underfloor ram

The following optional items are available:

- Isuzu Branded Mats
- Suspension Seat
- Satellite Navigation
- Reversing Aids
- Road Speed Limiter
- PTO Switch

For further information please contact your local dealer, ring us directly on

01707 28 29 30

or visit our website

www.isuzutruck.co.uk

ISUZU TRUCK (UK) LTD,
ISUZU HOUSE,
164 GREAT NORTH ROAD,
HATFIELD,
HERTFORDSHIRE AL9 5JN

ISUZU
BUILT AROUND U